

INKJET HEAD

High Quality & High Speed

CA4

“Higher Speed”



Features

- Higher driving frequency
- Wider range of grayscale up to 16 levels
- Accurate dot placement
- Oil based and UV curable ink available
- Stable jetting with water circulation thermal control

Higher driving frequency

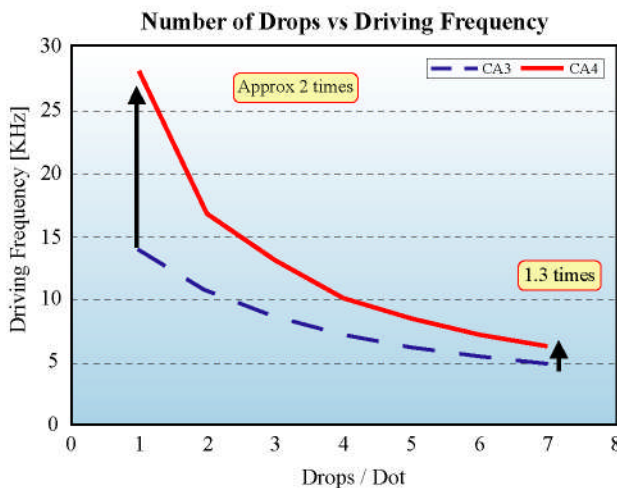

- 30% higher frequency of 6.2KHz at 7 drop (42pl) mode
- Twice as fast of 28.0KHz at 1 drop (6pl) mode

* pl = pico liter(s)
(10^{-12} liter(s))

Wider range of drop volume

The technology of jetting multiple drops within one dot allows for a wide range of grayscale, since each dot is created through a minimum of 6 pl to a maximum of 90 pl (15drops) of ink. Compared with conventional binary printheads, this grayscale printhead is more suitable to express smoother color gradation from applications.

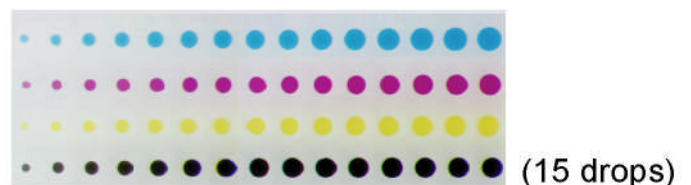

INKJET HEAD

High Quality & High Speed

SPECIFICATION

		CA4	CA3
Printable Width		53.6 mm	
Number of Channels		318 / head	
Resolution / Channel Pitch		150 dpi / 169 μm	
Print Mode		Multi drop 8 levels (Standard) 16 levels (Maximum)	Multi drop 8 levels (Standard)
Drop Volume		6 - 90 pl	6 - 42 pl
Standard Frequency	@ 1drop	28.0KHz	[13.8 KHz]
	@ 7drops	6.2 KHz	4.8 KHz
	@ 15drops	2.8 KHz	[2.6 KHz]
Linear Speed	@ 1drop, 1200dpi	35 m/min	[17 m/min]
	@ 7drops, 300dpi	31 m/min	24 m/min
Driving Voltage		14 - 31 V	14 - 28 V
Ink *		Oil based pigment ink / UV curable pigment ink	
Weight		148 g	
Dimensions		85(W) X 70(D) X 23(H) mm	
Cover		Yes	
Chassis		Ceramic chassis with water channel	

* pl = pico liter(s)

* Note : Phrase in parentheses is a reference value.

* Some ink may damage printheads depending upon the chemical used.

It is strongly recommended that material compatibility test be carried out before use to obtain optimum print performance of the printheads.

CA3 / CA4

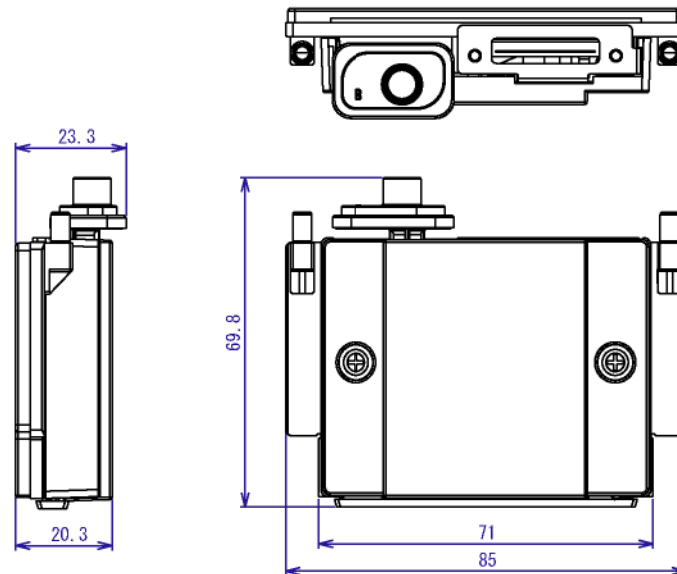

To ensure correct use of the product, be sure to carefully read the specifications and follow its instruction before use.

Disposal

The HEAD must be disposed of after removing the INK according to applicable laws and regulation in each country.

Design and specifications subject to change without notice. The color(s) of the actual product may vary from the color(s) shown in this brochure. All rights reserved. No part of this materials may be used or reproduced in any manner whatsoever without permission.

Copyright © 2007 TOSHIBA TEC CORPORATION